

REVISION HISTORY			
REV.	DESCRIPTION	DATE	DRAWN BY
1	ORIGINAL PRINT	9/3/2020	N. MASSOUDA
2	UPDATED TO AMDS-1	6/30/2022	T. JORGENSEN

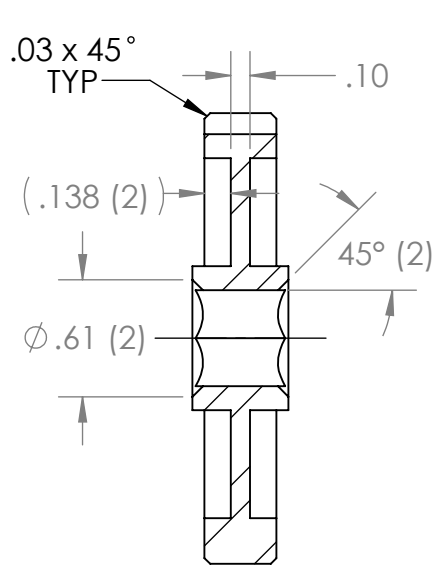

SECTION A-A

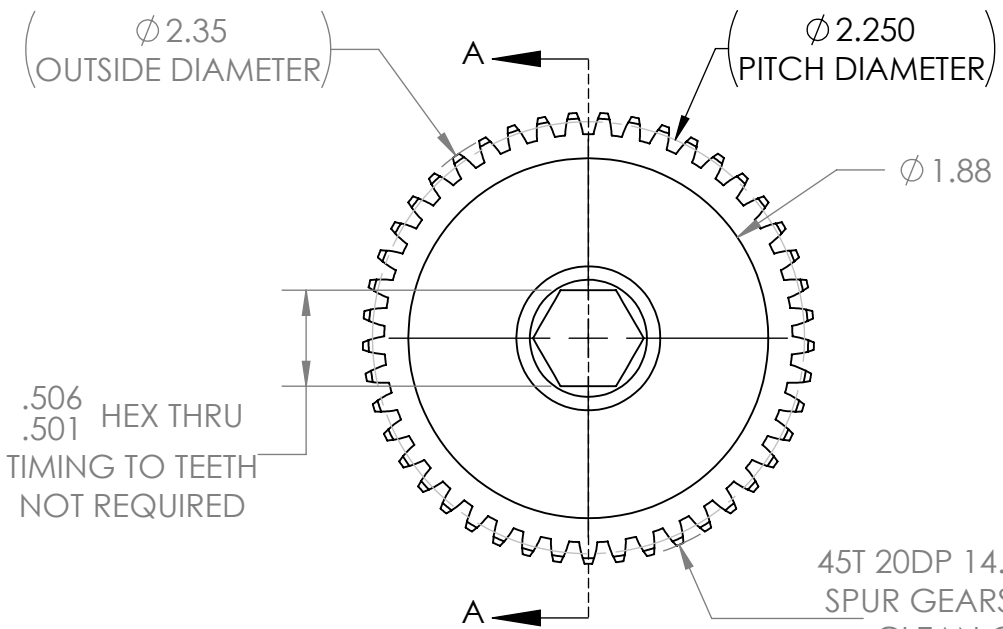

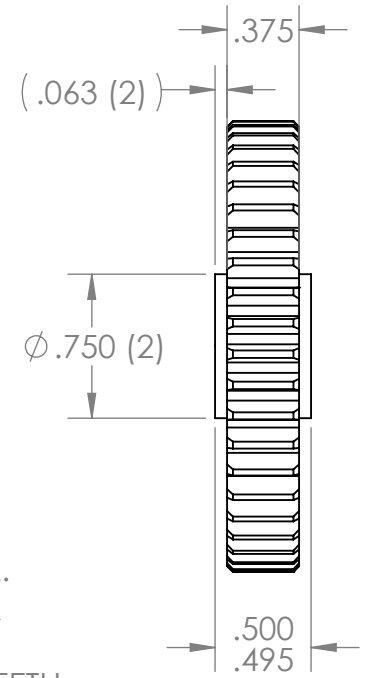

.506
.501 HEX THRU
TIMING TO TEETH
NOT REQUIRED

45T 20DP 14.5° P.A.
SPUR GEARSTOCK
CLEAN CUT
NO BURRS BETWEEN TEETH

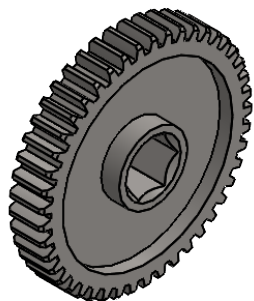

*** SEE CAD FOR ADDITIONAL TOOLPATH INFO***



UNLESS OTHERWISE SPECIFIED:		COMMENTS:				
DIMENSIONS ARE IN INCHES		DUAL DIMENSIONS ARE IN MILLIMETERS.				
TOLERANCES:		BREAK ALL SHARP EDGES		45T 20DP 14.5PA		
FRACTIONAL	±1/16			500IN HEX BORE GEAR		
ANGULAR: MACH	±1°			SIZE	DWG. NO.	REV
ANGULAR: BEND	±5°			A	am-4394	2
ONE PLACE DECIMAL	±0.1					
TWO PLACE DECIMAL	±0.01			SCALE: 1:1	WEIGHT:	SHEET 1 OF 1
THREE PLACE DECIMAL	±0.005					
FOUR PLACE DECIMAL	±0.0005					
MATERIAL	4140 STEEL	CHECKED	NAME	DATE		
FINISH	DEBURRED ZINC PLATED	ENG APPR.	NM	6/30/22		
DO NOT SCALE DRAWING		MFG APPR.				
		Q.A.				